

DESIGN & CONSTRUCTION OF NGONG SHUEN CHAU VIADUCT

CAO Shengfa
YWL Engineering Pte Ltd
Singapore

WU, Wilkie C O
China Harbour Engineering Co (Group)
Hong Kong SAR, China

TU Jing
YWL Engineering Pte Ltd
Singapore

WU, Eric C M
China Harbour Engineering Co (Group)
Hong Kong SAR, China

Summary

This paper covers the design and construction of the Ngong Shuen Chau Viaduct. First, it discusses the rationale and concepts of the alternative design, the selected bridge articulation and various salient design features to facilitate construction. Second, it describes the methods adopted for the construction of the foundation, substructure and superstructure of the viaducts. Special focuses are on the construction of the high-rise piers and portal structures at the portion linking with Stonecutters Bridge, the construction of the tight-curved segmental bridge across the existing West Kowloon Highway, the complexity of the construction works associated with segment erection sequence, geometry control, temporary works and temporary traffic and risk management.

Keywords

Precast Segmental Bridge, Monolithic Articulation, Geometry Control, Kinematics

1. Introduction

In the conforming design, Ngong Shuen Chau Viaduct (NSCV) [Figure 1] consists predominantly of bridge forms with typical 6-span continuous box girder decks supported on bearings. Various substructure forms are adopted: single piers, T-piers or portal structures. Large diameter bored piles are employed in the foundation. Based on a value engineering exercise, an alternative design using monolithic pier-deck articulation was proposed. Similar substructure and foundation concepts were employed. However, the alternative bridge articulation has rendered a fundamental change in the bridge behavior and stresses distribution, which would lead to some gains on material quantity, temporary work requirements and construction cycle time. The advantages of the alternative scheme are as follows:

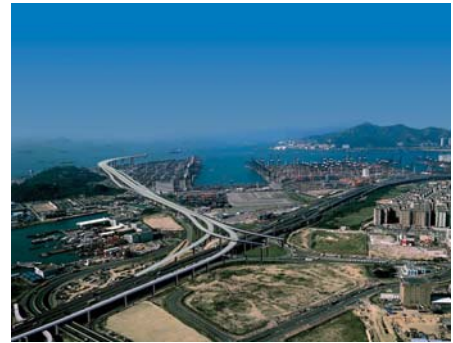

Figure 1 – Layout of Ngong Shuen Chau Viaduct

- a) Cost on bridge bearings can be reduced; less maintenance effort on structures.
- b) Total material quantity for substructure and foundation can be reduced without material increasing in the superstructure especially for high pier structures.
- c) Heavy pier segment can be eliminated; the cost for the lifting equipment and launching gantry can be optimized.
- d) Cycling time for each cantilever erection will be faster, as the pier segment erection and bearing installation has been eliminated/ de-linked from the erection critical path.
- e) Safer site operation can be achieved due to easier temporary works.

The alternative scheme is adopted in all structures except Bridge G1 across West Kowloon Highway, which is constructed as per the conforming scheme with bearing arrangement.

2. Viaduct Permanent Works Design

2.1 Structural Configurations

The Ngong Shuen Chau Viaduct consists of two types of structures, namely precast segmental and cast-in-situ bridge decks. The former is dominant form of the viaduct while the latter is used only in two ramps connecting the segmental decks to at-grade roads.

The precast segmental structure consists of 192 spans of single cell box girder. The total length of the box girder along its centerline is approximate 8.2km with maximum span length of 80m. The viaducts are formed by 39 sections of segmental bridges with 3- to 8-span continuous structures using nearly 2800 segments and 2 cast-in-situ bridges. The segmental bridges are supported monolithically at the intermediate piers and on bearings at both ends, except at the ramp structure (named Bridge G1) with minimum horizontal radius of 250m across and connected to the West Kowloon Highway, where bearings supporting the bridge deck are adopted.

2.2 Viaduct Superstructures

The precast segmental box bridges are typically 6-span continuous with span arrangement of 45m+4x60m+45m and constant beam depth of 3.2m [Figure 2]. The span depth ratio is 18.75. For span length greater than 60m and up to 80m, 4.2m height haunch segment is designed at pier to enhance the hogging moment capacity. The soffit of the haunch segment is constant and straight, unlike cast-in-situ balanced cantilever bridges, so that the mould for normal section can be utilized for the haunch segments.

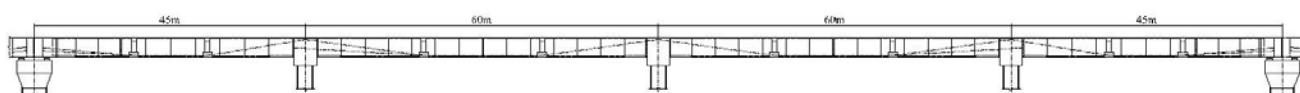

Figure 2 – Typical viaduct elevation

Three types of box sections are designed catering for the required carriageway width of 8.3m, 11.6m and 15.3m [Figure 3].

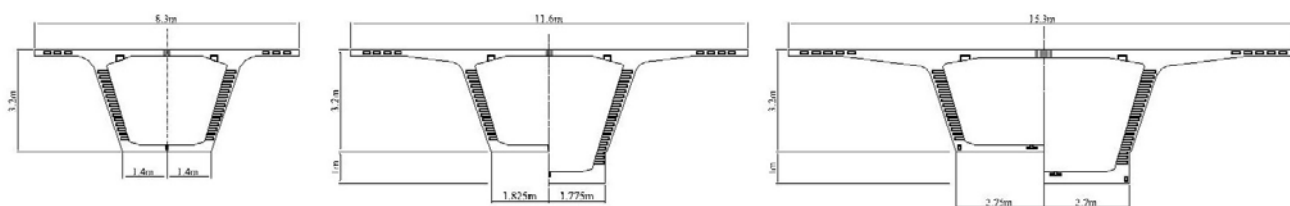

Figure 3 – Typical viaduct sections

The segmental viaduct incorporates prestressing system with a combination of internal and external tendons. The internal cantilever tendons are designed to carry the cantilever deck self weight and nominal construction live load, after formation of a continuous structure by stressing of internal continuity tendons, external tendons are applied to enhanced the structure for the service loadings. With the combination system, lesser tendons need to be embedded inside the concrete section during construction stage, the box soffit can be narrower to allow section with inclined webs, so that concrete sections and segment weight are reduced and limited to 125 Ton with max segment length of 4m.

All the internal prestress tendons are formed by 12 numbers of 12.9mm super strands. The largest external tendon consists of 43 numbers of the strands. All the tendons are stressed to 78% of the strand breaking load of 186KN. The ratio of the internal and external prestress is approximately 50 to 50. With the external tendon used, the viaduct decks are designed to satisfy both service limit state and ultimate limit state considering the incompatibility of the external tendons. The max external tendon length is approximately 330m with extension more than 2m.

External tendons are anchored on the end diaphragm of movement joint segments or at intermediate piers. Tendons are forced to deviate approximately at 1/3 of the span through deviator segments. Diabolo deviation duct are constructed on deviator segments to allow smooth transition of the external tendons.

Box sections are designed as reinforced member with road surfacing. During the design, it is found that for the cantilever slab of the box section under collision load of the vehicle on to the bridge parapet, large numbers of reinforcement has to be placed locally at the vicinity of the connection with the parapet.

To allow for the future replacement of the external tendons under live traffic, spare duct for the external tendon are provided. Clear working spaces are reserved behind the end diaphragm segments to allow for the operation. This arrangement requires larger crosshead to accommodate bridge bearings.

Balanced cantilever erection method is adopted in the precast segment erection. Segments are placed into position by launching girder or crane and wet-joined by using epoxy glues. Upon completion of two consecutive cantilevers, the box girder is then stitched at mid span by 200mm in-situ concrete.

2.3 Viaduct Substructure

Three types of structural forms, namely single pier, T-pier, and portal pier are constructed along the viaduct. They are all reinforced concrete structures with height ranging from 10m to 65m. Bridge substructure is formed as integrated monolithic structure with bridge deck through a precast segment at pier head [Figure 4], segments stitch to T-Pier [Figure 5] and portals.



Figure 5 – T-pier with bridge segments stitched



Figure 4 – Precast segment on pier monolithically

Segments in the cantilever span with pier head segment are matched without stitches whereas stitches of min 100mm are constructed between the first pair of segment and crosshead of T-Piers or portal pier. The monolithic connection between the bridge substructure and box girder eliminates significant amount of temporary works during cantilever erection and simplifies the erection method and the site operation is safer. On the other hand, the structures are more complicated, and more comprehensive behaviours with the interaction of the bridge superstructure, substructure and foundations must be carefully investigated for such type of structures during design.

In the permanent works design of a monolithic structure, the special structural behaviour is highlighted as follows:

- a) Significant amount of lock-in forces would be induced from monolithic structure due to prestress and its long term effect.
- b) Effectiveness of prestress in the superstructures would be reduced due to restraint from substructure and foundation.
- c) When multiple decks connecting to common crossheads, unfavourable stressing sequence would induce large percentage of prestress loss in the later stressed decks. And the deck stitching sequence is important.
- d) With combination of portal piers and single piers in one particular bridge unit, bridge deck would experience large in-plan bending under horizontal load (e.g. seismic load or typhoon) due to significant difference in stiffness of these two types of substructures.
- e) The monolithic crosshead would experience significant amount of torsion under longitudinal load (e.g. seismic load or typhoon) or initial strain effect (creep and shrinkage).
- f) Additional moment would be induced on to the bridge deck due to column deflection, especially for high columns.
- g) For high pier structures, with combination of monolithic piers and piers with bearings, lock-in movement at bearings would be significant due to deformation of pier under prestressing parasitic effect.
- h) Lock-in force induced from launching gantry (placed before formation of continuity and released after continuity) and the impact on bridge bearings would be significant.
- i) Moment distribution along the piers is much related to the stiffness of foundations. With less stiff foundation selected, larger longitudinal bending moment will flow to the connection between the substructure and superstructure.
- j) Additional moment for high columns should be considered for the combined stiffness of column and foundations, especially when less stiff foundation are constructed.

Hollow column are constructed for high piers. For pier height up to 55m, the column size of 4.8mx4.0m is adopted. Solid column (with minimum size of 2.8mx1.2m) of less longitudinal stiffness are adopted for low piers or piers further away from expansion-contraction neutral point of a bridge unit. For very stiff short piers, bearings are adopted so as to release the lock-in forces in the structure.

2.4 Viaduct Foundations

Viaducts are founded on pile foundation socked into Grade III rock or better. All the piles are designed as end bearing pile with the contribution of the shaft friction and end bearing capacity in the rock. Piles of diameter range from 1.5m to 2.5m with concrete grade of 40Mpa. Each pier of the viaduct is supported by a pile group consisting of 2, 3, 4 or 5 numbers of bored piles. Some piers are supported by single piles of diameter of 2.5m.

Pile foundation design has taken into account of the interaction with existing adjacent structures, and future tunnelling works. At area where the foundation are close to existing underground structures, isolation material around the pile cap and pile shaft are constructed to release the shaft friction between the pile and the soils. At area where there will be future tunnelling works, additional axial load due to negative skin friction are designed. Piles closed to the future tunnelling works, denser reinforcement are provided at lower portion of the piles than upper portion, instead of introducing of additional piles to take the extra loadings. The piling design implemented a cost comparison process comparing different diameters of piles and number of piles for generic pile group in order to achieve the most economic design.

For bridge structure with varies pier heights, in order to minimize the lock-in stress due to deck elastic shortening, creep and shrinkage, and seasonal temperature changes, the stiffness of the pier and foundation shall be properly designed and chosen. For a typically 6-span continuous structure with similar height of the piers, the bridge contraction neutral point is located at the centre piers, at piers further away from the neutral point, larger deformation will be accumulated under the above mentioned initial strain effect. If the total stiffness of the pier is too stiff, significant force will be generated. The force will be the flexural bending moment and significant longitudinal shear on the piers. Same magnitude of the moment will be acting onto the bridge deck and similarly a tensile axial force will reduce the effectiveness of the prestress in the deck. Therefore, piers further away from the neutral points shall be designed with less stiffness in bridge longitudinal direction, so single pile or 2-pile foundation has been adopted for viaducts with relatively lower piers. When the piers are higher than 35m, the structural stiffness can be controlled by selection of the column size, pile foundation with minimum 3 piles for such pier are constructed so as to achieve the stability of the bridge structure during balanced cantilever erection.

The viaduct bridges are designed to resist the horizontal seismic load equivalent to 0.05g of the ground acceleration, in order allow the bridge structure to be adequate under external horizontal load, larger column section together with foundation with more piles are constructed for piers close to the bridge contraction neutral point.

For balanced cantilever constructed bridge structures, the design must satisfy both temporary and service conditions. For monolithic structure, the less stiff pier would be benefit for the service condition, however, at erection stage stiffer pier would be required to ensure the safety of construction. Contractor has to achieve the balance in satisfying both conditions. For areas where temporary works can be derived at low cost, satisfying the service condition is the first priority; for areas where the temporary works would be costly, the foundation and substructure have to be designed for the temporary conditions. For the curved bridges across West Kowloon Highway (WKH), the bridge substructure and foundation are designed to take one segment out-of-balance, because temporary works would be costly at West Kowloon Highway [Figure 6].

However, at ramps approaching ground roads, temporary mobile tower less than 10m height is used, instead of design a stiff foundation system to cater for one segment out-of-balance erection by use of mobile crane [Figure 7]



Figure 6 – Erection of segment by launching girder over WKH



Figure 7 – Erection of segment by crane

3. Viaduct Temporary Works Design

During balanced cantilever erection, the structural behaviours of the partially completed permanent structures are different from their service conditions. In this project, types of temporary works systems have been developed in order to cater for the different structure configuration and particular site constraints. In general, the major temporary works consist of the following:

3.1 Temporary Platform System for Precast Concrete Shell Installation

In this project, some of the pier segments are formed by a precast concrete shell with insitu concrete infill in order to form a monolithic connection with the pier. The concrete shell is prefabricated in the casting yard and erected by crane onto the temporary platform system, which is pre-mounted on the pier head. The temporary platform system is also equipped with vertical and horizontal hydraulic jacks for geometry adjustment [Figure 8].

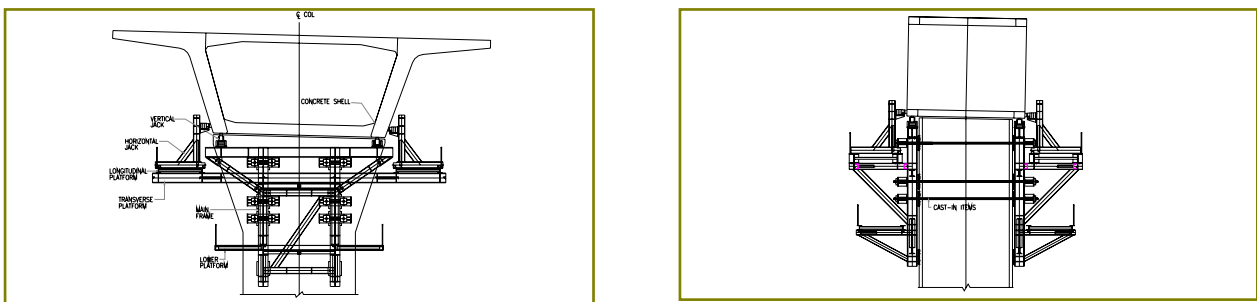

Figure 8 – Temporary platform system for construction of segment on pier

3.2 Temporary Stabilization System For Balanced Cantilever on Bearings

Where the bridge deck is rest on bearings, a temporary stabilization system is required to facilitate the balanced cantilever segment erection. The typical temporary stabilization system consists of vertical tie down system between pier segment and pier head, vertical & transverse jacks on pier head, temporary steel bracket mounted to the pier with off pier vertical jacks and tie system as well as longitudinal restrain [Figure 9].

The system is designed to take care of varies load cases such as: one segment out of balanced at the same side of steel bracket, unbalanced construction live load (0.5kN/m²), 2% different weight of balanced cantilever and unsymmetrical wind load, etc.

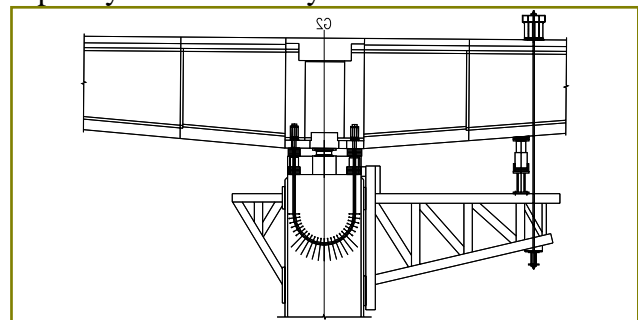

Figure 9 – Stabilization system for cantilever on bearings

3.3 Temporary Tower for Erection of Long Cantilever Structures

Temporary tower are provided if the pier stabilization system or pier is unable to resist big unbalanced moment during T-structure erection stage for long cantilever structure or tight – curved bridge. The temporary tower can be either supported by the ground foundation [Figure 10] or erected deck underneath.

On top of the tower, vertical jacks and tie down system provide the resistance of out of balanced force from deck whatever it is uplift or downward force.

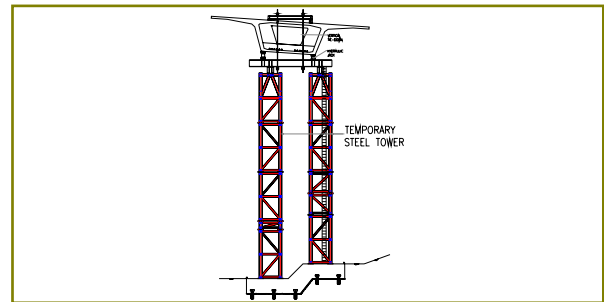
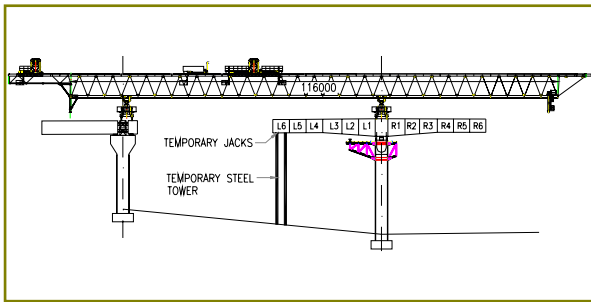

Figure 10 – Temporary tower for long cantilever segment erection

3.4 Temporary Clamping System for Closure of Middle Stitch

When two adjacent cantilevers are completed, deck continuity will be obtained by closure of the stitch which will be cast in-situ. Before stitch closure, the span geometry shall be adjusted and secured by a temporary clamping system [Figure 11]. It will support the stitch formwork and the weight of the stitch during casting stage.

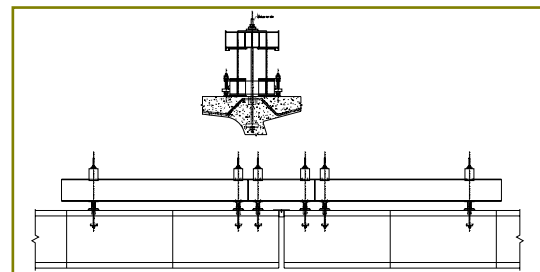

Figure 11 – Clamping system for closing stitch between cantilever decks

3.5 Movement Joint Temporary Steel Frame For LG Support And End Diaphragm Segment Stability

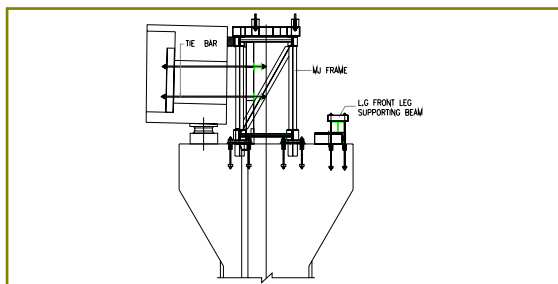

Figure 12 – Steel frame for end segment erection

The movement joint temporary steel frame [Figure 12] provides the support to the LG middle support as well as the stability of the end diaphragm segment before permanent bearings grouted.

The MJ frame has to be tied to the pier head with cast in bar to resist the uplift force after LG positioned on top under typhoon condition.

3.6 Temporary Works for Bridge G1

The Bridge G1 is a 5-span continuous segmental bridge with 250m horizontal radius. The mid-pier segments are rest directly on the bearings and hence the fixity of the T-structure during erection stage shall be ensured. During whole erection stage, the following temporary works were mobilized:

- Different types of temporary steel brackets on the various pier heads;
- Temporary ground tower was employed under particular segment of pier;
- Stabilisation frame for end span segment erection and diaphragm segment fixity;

Due to the curvature effect, the pier heads were deformed transversely and they were all toward the inner curvature of the bridge. The value of the transverse deflection varied depending on the span configuration and structural articulation. For the second and third piers, the values of the transverse deflection are different about 35mm and would cause problem to the horizontal alignment during the stitch closure. To overcome this problem, transverse preset for pier segment and pier was proposed and adopted. The preset values were obtained from an accurate structure model with the consideration of each construction stage. By doing this with the erection geometry control monitor system, all the adjacent cantilever tips were matching perfectly.

4. Viaduct Construction

4.1 Foundation

There are over 400 nos. of large diameter bored pile with diameter range from 1.5m to 2.5m for the foundation of the Viaducts. The pile depths range from 12m to the deepest of nearly 90m. The Contractor deployed a specialist piling subcontractor using rotary drilling rigs to construct the piles. Bentonite slurry was used for stabilization of pile shaft in excavation. As temporary casing were not necessary for pile shaft excavation, the production rate of piles with medium depth (40m to 50m) could be maintained at 4 days per pile in general. To pace with the fast track piling works, design works had to be carried out round the clock in order to meet the progress.

Upon completion of piles, pile caps were constructed by using conventional method. As majority of the pile cap locations are in the vicinity of existing structures such as railway, bridges and underground drainage culvert in the region, hydraulic sheetpiling machine was deployed to install and extract sheetpiles for excavation of pile cap to minimise undue disturbances to the adjacent structures.

4.2 Substructure

The heights of piers for the Viaduct range from 3m to 55m. The low and medium height piers are constructed by using conventional jump form and scaffolding methods. Steel truss supported on completed column or ground towers are also used as falsework for the construction of some portal beams and crossheads.

In the section joining the Stonecutter Bridges, the contractor use self-climbing formwork system and plate girder falsework to construct the columns and portal beams respectively with height more than 50m. The self-climbing formwork system equipped with winched lifting device, which is raised up along the column by hydraulic means with a structural frame mounted on top of the previous pour, reduce the use of crane for steel fixing and formwork assembly and also save time to erect working platform as well. In general, 3-day cycle for 4.5m pour height can be optimised [Figure 13].



Figure 13 – Self-climbing form for construction of column

The plate girder falsework system with self-weight of 450 ton also equipped with gantry crane for material lifting works is used to construct the portal beams on top of the high columns. The system consists of two plate girders with structural steel bearers to form the main falsework supporting the concrete load of 900 cu.m. of portal beam in typical sizes of 44m x 3.7m x 5.5m.



The falsework is raised and lowered by series of hydraulic jacks with high strength lifting bars fixed on two lifting frames mounted on the top of the columns. The plate girder is fixed in position at the top by anchoring to eight pin joints, which was designed to take 2,500 ton, cast in each wall face of the two portal columns. Hoisting of materials for the construction of portal beam is carried out by use of the gantry crane mounted on the plate girder [Figure 14]. Concrete is placed by use of 4 concrete pumps within 10 hours in a single pour.



Figure 14 – Plate girder falsework for construction of portal beam

4.3 Superstructure

For erection of precast bridge segments, different methods are adopted to suit the articulation of the bridge structures, site constraints and programme of works. Major methods are illustrated as below:

Segment structure	Segment on single pier	1 st pair segment stitch to T-pier	Segment of typical span
Erection method	Place precast segment shell by crane and cast segment core with pier monolithically.	Place pair of segment by lifting beam and stitch to T-pier with insitu concrete.	Place segment by launching girder or crane
			

Both the first two methods are adopted for advance completion of segment erection works in which longer cycle time for insitu concrete stitching involved. By the completion of them, the subsequent erection rate of remaining segments for the same cantilever span by launching girder could then be optimised.

Before segment erection takes place, launching girder kinematics are designed in details by taking into account the structural capacity of the plant used, locations and magnitude of loads imposed on the permanent structures. For the construction of balanced cantilever segmental bridge, precise geometry control for erected bridge deck is formulated. By taking into account the elastic deformation of the superstructure and substructure during every stage of segment erection due to the self-weight of superstructure, superimposed dead load and prestressing with the as-cast span geometry, target geometry data is developed for erection operation. During each span erection, survey data of the respective erected segments at each critical stage is taken for review and adjustment. When out-of-tolerance geometry observed, thin shim plates made up of the same epoxy glue for segment wet jointing are fixed between the respective segment joints for geometry correction.

For the construction of in-situ stitch between two continuous cantilever spans, control of time for concreting and curing with respect to the difference of ambient temperatures during the period are critical. To avoid any crack develops on the stitch joints before prestress put in place due to contraction of two isolated and massive structures during the period between concrete casting and curing (normally 12 hours), stitch concrete are cast at night time and cured overnight during the period when ambient temperature difference is less comparable with day time (particular at summer).

5. Segment Erection over West Kowloon Highway

Segment erection work of three bridges namely G1 (linking the main viaduct to the West Kowloon Highway), ML16 and ML15 (connecting the main viaduct with Lai Chi Kok Viaduct by crossing West Kowloon Highway) has to be carried out over the West Kowloon Highway (WKH) where the Airport and Tung Chung Line of the Mass Transit Railway aligns underneath. The work is classified as an extremely high risk construction activity. The Contractor with the Client, Consultant and Traffic Management Liaison Group has conducted different control measures for the works. Construction time constraint, risk assessment, preventive and mitigation measures, and contingency plans have been considered and implemented.

5.1 Construction Time Constraint

As a matter of safety concern during segment erection works over traffic on WKH, the contractor had to divert the traffic away from the construction points wherever there involved lifting loads or movable objects above or adjacent to WKH and the nearby roads by temporary traffic management schemes with either lane(s) closure or carriageway closure.

5.1.1 Constraint from Traffic

The result of Traffic Impact Assessment (TIA) evaluated that any road closure of West Kowloon Highway should be carried out from midnight to early morning [**Figure 15**]. For other roads in the vicinity, road closure time was only allowed from 10:00 pm to 5:30 am. The TIA Report also concluded the contingent scenarios that if WKH cannot be re-opened to traffic by 5:30 am, traffic queue of 3 km would occur in the morning peak hours. For full road closure of WKH, extra time should be reserved for decommissioning of temporary traffic arrangements such that the construction works should be completed before 5:00 am.

5.1.2 Constraint from MTRC

At each bridge, any segment erection within the MTRC Airport Railway boundary was not allowed until the railway was out of service, i.e. between 1:00 am to 4:30 am.

5.1.3 Time Breakdown for Segment Erection Work

Based on different time constraints, detailed working time schedules for the respective temporary traffic arrangements and sections of erection works were developed for the timely completion of works. Time schedules with breakdown to minutes were formulated for the major activities including commissioning and decommissioning of TTAs, segment transportation, erection and prestressing works of individual segment.

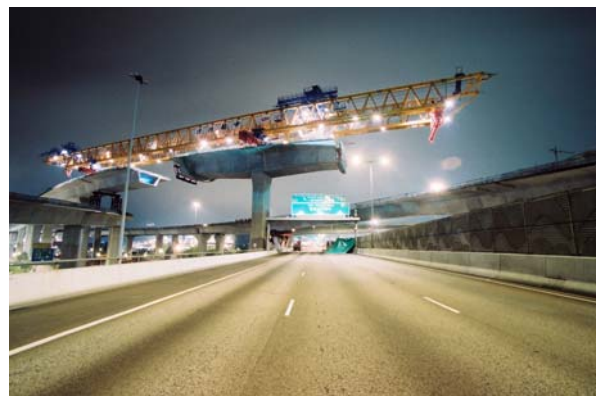

Fig15 – Segment erection over WKH



5.2. Risk Preventive and Mitigation Measures

Before commencement of the works, risk assessments on temporary traffic arrangements and construction safety were conducted and evaluated in details. According to the potential risks as identified, different preventive and mitigation measures were developed in order to ensure the works to be carried out in safe and timely manner.

5.2.1 Construction

Although live traffic would be diverted away from the work front, falling of any heavy object to WKH was still a major concern of all involved parties. In managing this risky activity, preventive measures were established.

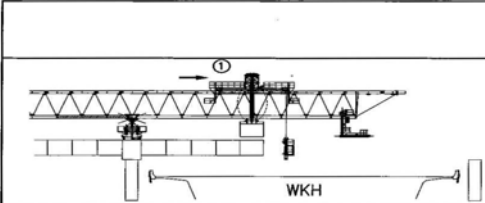
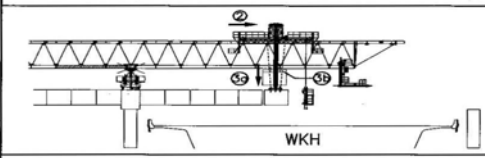
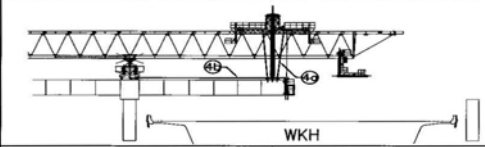
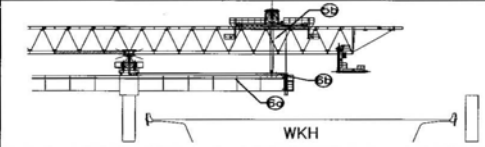
- All lifting appliances and gears used for the segment erection works were re-examined and re-tested by appointed competent person, where practical, .were replaced with new ones.
- In addition to the lifting winch of the launching girder with designed safety factor of 4, extra wire ropes anchored from the winch hoisting beam to the segment lifting beam were used as secondary safety device for segment manoeuvring throughout the erection process until permanent prestress in place. Assessment of safety measure for a typical operation is illustrated below:

	DESCRIPTION	DURATION	SAFETY MEASURE ACTIVATED OVER WKH				
			SHELTER BY ERECTED DECK	WINCH	SECONDARY WIRE ANCHOR	TEMPORARY PT FIXING SYSTEM	PERMANENT C-TENDON
	① LIFT THE SEGMENT TO CANTILEVER TIP OVER ERECTED DECK	15 MINS	✓	✓ FOS=4			
	② LIFT AND TRANSPORT LONGITUDINALLY THE SEGMENT TO POSITION	1 MINS		✓ FOS=4			
	③ a) LOWER DOWN THE SEGMENT TO POSITION b) INSTALL SECONDARY WIRE ANCHOR	2 MINS 3 MINS		✓ FOS=4			
	④ a) SECONDARY WIRE ANCHOR ACTIVATED b) APPLY EPOXY AND PT BAR STRESSING	40 MINS		✓ FOS=4	✓ FOS=1.5		
	⑤ a) PT BAR ACTIVATED b) RELEASE SECONDARY WIRE ANCHOR c) C-TENDON THREADING AND STRESSING	90 MINS		✓ FOS=4		PT BAR ✓ FOS=2	
	⑥ a) C-TENDON ACTIVATED. LOAD TRANSFERED TO PIER b) REMOVE WINCH FROM SEGMENT	N/A			PT BAR ✓ FOS=2	✓	
Upchainage span – Typical, 6th pairs and above							

5.2.2 Traffic

Check points were established at the critical times according to the construction activities as scheduled. The 1st check point was set at 9:00 pm to confirm commencement of works by considering the traffic and weather conditions. The 2nd check point was set at 1:00 am to confirm the completion of first segment erection. If insufficient time is anticipated for continual erection of the second segment, the works would be postponed. The 3rd check point was set at 4:00 am to review the progress of second segment erection. If the situation was found to be unsatisfactory, the established Operation and Traffic Contingency Plan would be activated to ensure timely opening of the road to public.

5.3. Contingency Plans

In order to manage various expected scenarios, this may affect normal execution of the works when occurred, contingency plans on aspects of plant and traffic were established.

5.3.1 Mechanical Breakdown

Various scenarios and the corresponding rectification actions had been defined in case of mechanical breakdown of the hoisting equipment of the LG. The following is one of the scenarios.

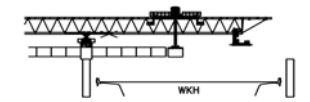
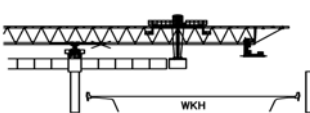
Scenario - The lifting winch broke down and the segment was being suspended above WKH.	
Corresponding Rectification Action - Secure the segment with the secondary safety wire ropes and repair the winch when circumstances allow.	

5.3.2 Emergency Traffic Arrangements

All TTAs were implemented with a corresponding Traffic Contingency Plan which was drawn up to cater for any possible occurrence of incidents which might hinder the re-opening of WKH as scheduled. Throughout the construction of Bridges G1, ML15, and ML16, 37 nos. of TTA and 6 Traffic Contingency Plans had been prepared.

As WKH is critical to the traffic network in the districts, a Traffic Panel and a Control Centre were set up during full closure TTA on WKH implemented which functioned as the commander for overall traffic control and the First Contact Point to all Government Departments and Public Authorities when traffic could not be opened on time. This Panel consisted of the representative from the Hong Kong Police Force, Highways Department, Consultant and Contractor on site for the monitoring of the road closure / road re-opening works. All segment erection over WKH has been carried out in a safe manner and there was no major delay on road reopening recorded at the three separate crossing operations.

6. Conclusion

With nearly 70% of bridge segments erected, the Ngong Shuen Chau Viaducts are due to complete by early 2007. The construction of the viaducts is considerably facilitated on the aspects of constructability and programme by the integration of both permanent structure design and construction methods and plant being adopted. Technical challenges on design and construction works as well as social and environmental issues arisen during the course of works are envisaged and resolved proactively by all stakeholders involved in the Project. The successful completion of the three bridge segment erection works over the West Kowloon Highway with minimal disturbances to the public is one of the worthy experiences.